

13. Any ducting used must be free of blockages.
14. The room where the product is operating must have adequate air replacement to ensure maximum effectiveness.
15. If the product is sited in a room containing a fuel burning appliance which is not of the balanced flue type, the installer must ensure that air replacement is adequate both for the fan and the fuel burning appliance.
16. The product must **not** be used as an activator for water heaters, stoves, etc.
17. The product must **not** exhaust into ducts designed to evacuate fumes from combustion in stoves or other combustion-powered devices.

INSTALLATION

Installation must be carried out by a properly qualified person.

1. Remove the fan from the box, taking care to dispose of the packing material properly.
 2. Check the location of existing wiring for ease of connection.
 3. For optimum performance site the fan a minimum of 2.3m above ground level.
 4. In the wall or ceiling, cut a hole 100mm dia, taking care to allow any necessary space for ducting. For any other wall or ceiling installation check sizes before cutting hole. **It is the installer's responsibility to use the appropriate core cutter to obtain the correct hole diameter.**
 5. Dismantle the fan:
 - a. Remove the Front (3) by unscrewing Front Fixing Screw (1)
 - b. Using the Motor Fan Assembly (4) of the fan as a template, mark the hole drilling positions to fix the fan to the wall or ceiling (N.B use the holes already knocked out in the top right and bottom left corners of the back of the Motor Fan Assembly (4).
 - c. Drill the 6mm dia holes
 - d. Using the wall plugs and long screws provided, fix the Motor Fan Assembly (4) of the Fan to the wall/ceiling
 6. **NOTE:** Before fixing the fan to the wall, decide whether to have the cable entering the fan through the knocked-out hole on the top of the Motor Fan Assembly (4) or whether through the back of the Motor Fan Assembly (4). In the first case the cable clamp provided will need to be used. In the second option the cable entry hole will need to be knocked out.
 7. Select the lower, continuous speed at which the fan is to operate by means of the jumper switch (Fig 5). The fan is supplied with the jumper switch on one pin (Fig 6) - this is the position for Speed 1 (lowest speed). For Speed 2, the switch needs to cover both pins (Fig 7)
 8. Connect to the electricity supply via a double pole switch of a suitable size, with contact openings of at least 3 mm (see wiring options). The type of cable to be used is shown in Fig 4. If using the fan **without** the cord, the cord should be in the "off" position, the cord cut off, and the fan wired as required (see Figs 3 or 4).
 9. **THESE FANS ARE DOUBLE INSULATED AND DO NOT REQUIRE TO BE EARTHED**
 10. Fix back the Front (3) of the Fan.
- N.B This fan is NOT suitable for use with a Gravity Grille. It should be installed using either a Cowl or Fixed Grille.**
11. For window installation see separate instruction leaflet with (optional) window kit - ECOWK10/4

CLEANING AND MAINTENANCE

1. Before any maintenance or cleaning operation, switch off the fan and disconnect it from the main power supply.
2. The front cover can be cleaned with a dry cloth. Any other maintenance or cleaning should be carried out by a suitably qualified person.
3. The motor fan assembly can be cleaned with a dry brush or dry cloth. Ensure that it does not come into contact with any kind of liquid or solvent. If this should occur, contact a qualified technician before reassembling the fan.
4. Electrical parts cannot be cleaned

NOTE: The motor does not require lubrication as it is maintenance free "sealed for life" type.

Vectaire Ltd, Lincoln Road, Cressex Business Park, High Wycombe, Buckinghamshire, HP12 3RH
Tel: +44 (0)1494 522333. Fax: +44 (0)1494 522337. Email: sales@vectaire.co.uk



& O.E.E

"ECO1003"

Energy Efficient 3 Speed Wall/Window Axial Fan



Installation Instructions

- **for toilets, bathrooms, shower-rooms, utility rooms and kitchens**
- **wall, ceiling, panel or window (with optional kit) installation**

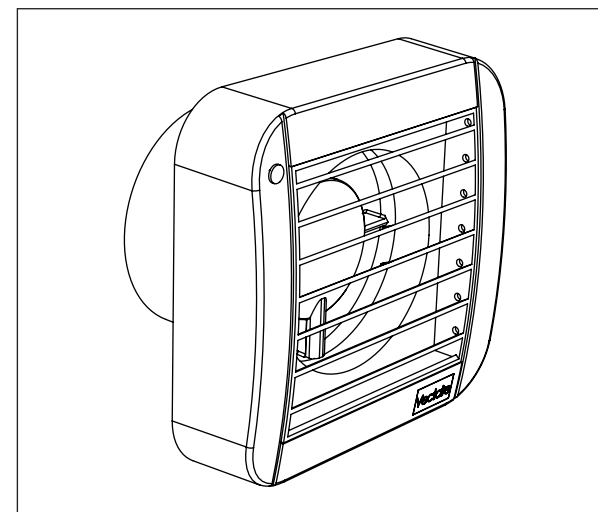

CE  IPX4

“ECO1003” - ENERGY EFFICIENT AXIAL FAN INSTALLATION and OPERATING INSTRUCTIONS

PLEASE READ THE FOLLOWING INSTRUCTIONS VERY CAREFULLY BEFORE USING THE PRODUCT. THE MANUFACTURER WILL NOT BE HELD RESPONSIBLE AND DECLINES ANY AND ALL LIABILITY FOR DAMAGE CAUSED TO PERSONS OR PROPERTY DUE TO IMPROPER USE WITH REFERENCE TO THE PRECAUTIONS OUTLINED IN THIS MANUAL. **THIS MANUAL MUST ALWAYS BE READILY AVAILABLE.**

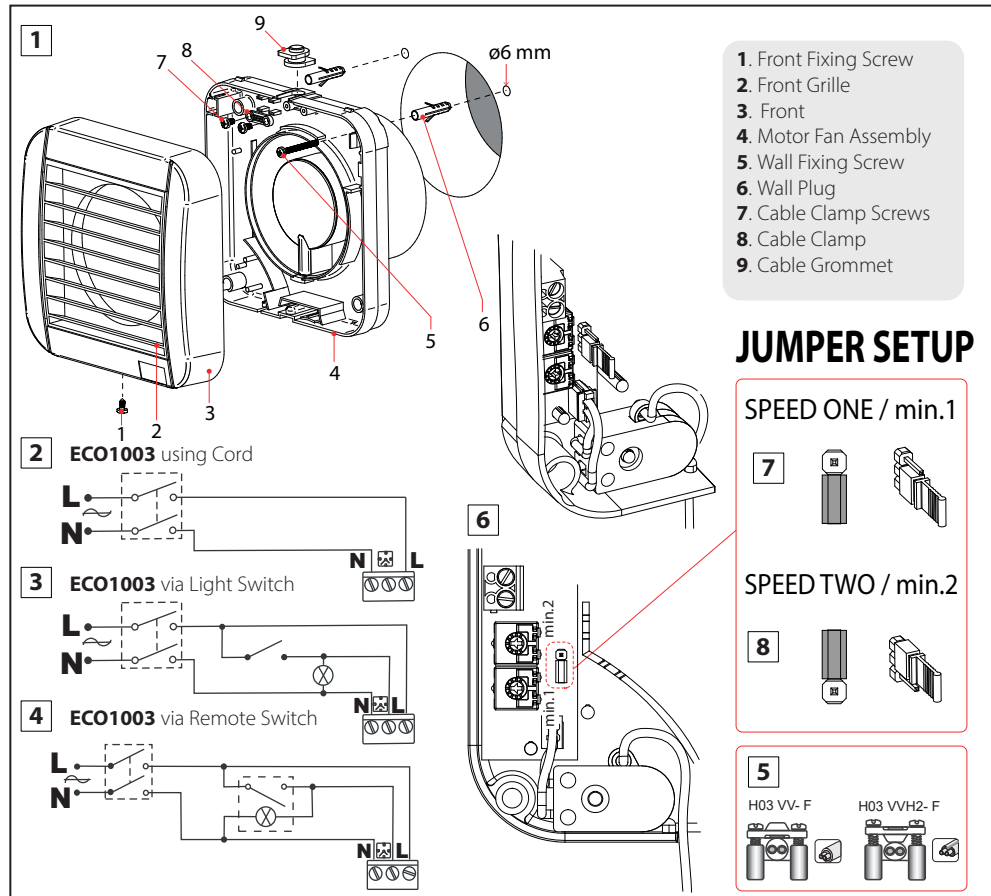

DESCRIPTION AND USE

The ECO1003 is an axial fan for extracting directly outside or through a short length of ducting. The fans are suitable for walls, panels or ceilings (cord operation not recommended for ceilings); and for windows with the optional window kit - ECOWK10/4.

This fan is a quiet running, 3 speed fan. It is designed to run continuously at one of a choice of 2 lower speeds fixed at installation using jumper switch (Fig 6) - Fig 7 Speed 1 - lowest speed: Fig 8 Speed 2. The user can boost the fan speed to its maximum performance when required.

ECO1003CLV - SELV 12v model - also available.

GENERAL PRECAUTIONS

1. This leaflet explains how to install correctly, use and maintain the product. Following these instructions will ensure the reliability of the product and extend its working life.
2. The product should not be used for any purpose other than that for which it was designed and as described below.
3. Remove the product from its packaging and make sure that it has not been damaged. If in doubt, contact the supplier, authorised dealer, service centre or manufacturer to check that the product will still operate correctly. Do not attempt to use or repair the product before doing this.
4. Do not leave packing material within the reach of children or unskilled people, or dump any hazardous parts into the environment (polystyrene, plastic, polypropylene, etc.).
5. The use of any electrical produce requires compliance with some basic rules which are listed below:
 - do not touch it with wet or damp parts of the body (e.g hands, feet).
 - this appliance can be used by children aged from 8 years and above and persons with reduced physical, sensory or mental capabilities or lack of experience and knowledge if they have been given supervision or instruction concerning use of the appliance in a safe way and understand the hazards involved. Children shall not play with the appliance. Cleaning and user maintenance shall not be done by children without supervision.
6. The product should be connected to the mains electricity supply or electrical outlet only if:
 - the electrical voltage and frequency correspond to those shown on the rating label.
 - the capacity of the electricity supply is sufficient to operate the product at its maximum power.
 - suitable electrical protection must be provided for the product to be installed.
7. The electrical supply to which the fan is connected must comply with all existing regulations. All installations must comply with current IEE wiring regulations
8. Before maintenance or cleaning is carried out, the product must be switched off and disconnected from the mains electricity supply.
9. If a fault, malfunction or anomaly of any type occurs, the fan should be isolated (by turning off the switch and by disconnecting it from the mains electricity supply) and advice sought from qualified personnel.
10. Always request original spare parts to effect any repairs.
11. If the product needs to be removed, turn off the mains supply circuit-breaker and then disconnect the fan.
12. The fan **MUST BE** installed as detailed in the **INSTALLATION** section below.

SPECIAL PRECAUTIONS

1. This product is professionally manufactured and complies with the current standards regarding electrical equipment.
2. The product complies with the Low Voltage Directive and with Directive EMC 2014/30/EU for the Suppression of Radio Interference.
3. The product should **not** be used in an ambient temperature higher than 40°C (104°F).
4. The product should **not** be exposed to atmospheric agents (rain, sun, snow, etc.).
5. The product or any part of it should **not** be placed in water or other liquids.
6. Routine maintenance as described below should be carried out to check the condition of the fan.
7. To avoid the risk of fire, do **not** use the product in the presence of flammable substances or vapours such as alcohol, insecticides, petrol, etc.
8. The air or fumes being extracted must be clean and free from greasy particles, soot, chemical and corrosive agents, flammable or explosive mixes (If these substances are to be extracted, contact an authorised dealer for specific range of explosion-proof products).
9. **The product must be installed by professionally qualified personnel. Incorrect installation can cause damage to people, animals or property, for which the manufacturer cannot be held liable.**
10. The product must be connected to the electricity supply via a double pole switch of a suitable size, with contact openings of at least 3 mm.
11. If the electrical supply board (or switching device) is located some distance from the fan a means of local isolation must be provided.
12. To ensure optimum operation, do not block the air intake and exit vents.